

(1) Application No. 0211423A	(21) INT. CL. ⁷ A61M 15/00
(2) Date of filing 29.03.1992	(22) UK CL. (Edition I) AST TBO TBE
(3) Applicant Hormel Healthcare Limited (Incorporated in the United Kingdom) Orchard House, Pine Meadow, Marlow, Bucks, OX19 6JY, United Kingdom	(24) Documents cited GB 2204789 A GB 1352791 A GB 1352871 A GB 1352871 A EP 0404113 A1
(7) Inventor Michael John Holroyd	(23) Field of search UK CL. (Edition I) AST TBO TBE INT. CL. ⁷ A61M
(8) Agent and/or Address for Service Crompton & Lord 81 Whitehall Street, London, WC2E 8AH, United Kingdom	

(54) Mechanical Inhaler device

(57) An inhaler device for use with a drug delivery system, e.g. an aerosol container, comprising a housing 400 for receiving said container, having air inlet slots 420 and a mouthpiece 405 through which a dose of medicament contained in an air flow is inhaled. A breath actuated release lever 602, in one condition, closes the air inlet slots 420 to inhibit ingress of foreign matter therethrough, and, in a second condition, actuates a release mechanism 640, 406 to release a spring 430 to cause actuation of the second container. The lever 602 in the second condition opens a valve port in a diaphragm 440 to vent an underpressure developed between the diaphragm and top of a sliding sleeve 420 and acting to counter or partially counter the force of the spring 430 thereby allowing the spring to urge the sleeve 420 and the aerosol can downwardly to dispense the medicament. The drug delivery system may comprise a dry powder dispenser instead of an aerosol.

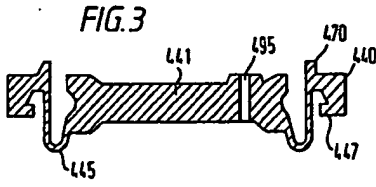
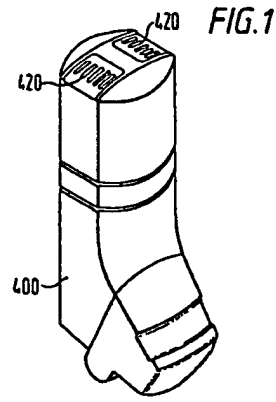
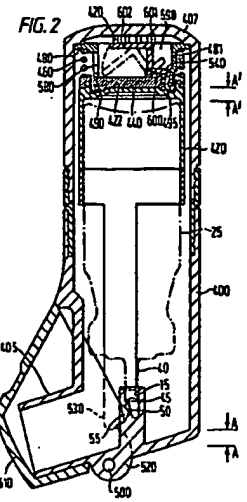

GB 2 264 238 A

At least one drawing originally filed was reduced and the print reproduced here is taken from a later filed format copy.

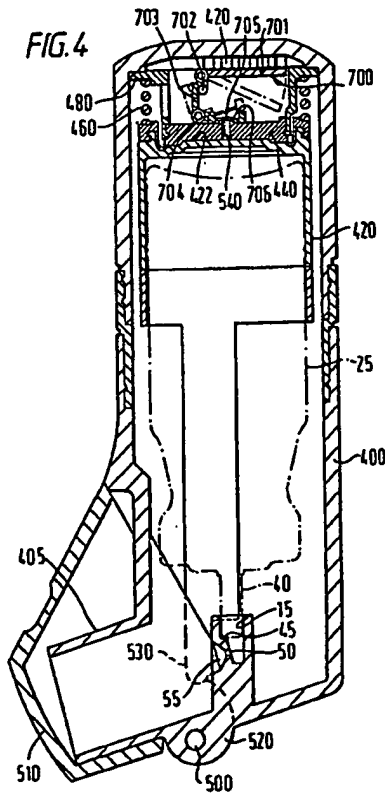
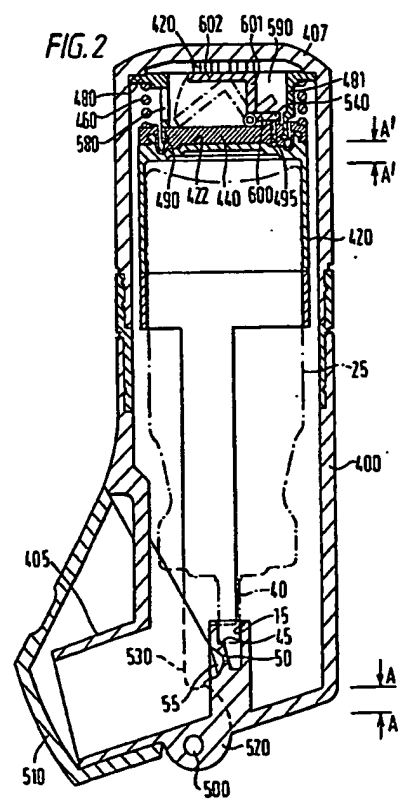

MEDICAMENT DISPENSING DEVICE

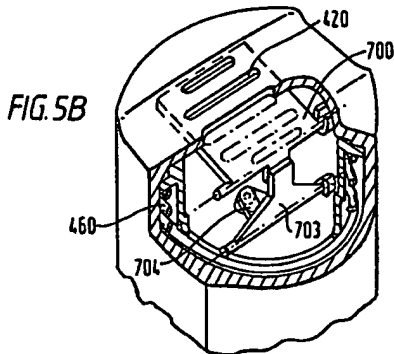
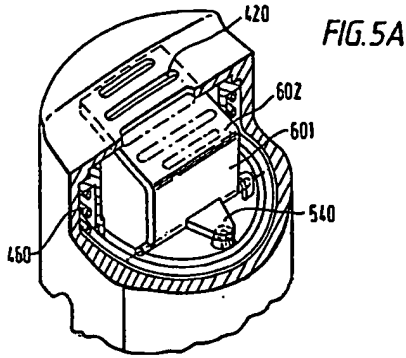

2

EP-A-0045419 describes an inhalation device having biasing means which are alone of insufficient force to depress the container but which together are of sufficient force to do so.

EP-A-186280 describes a device which employs magnets to control the release of the aerosol container.

US 3605738 describes devices in which the aerosol container communicates with the mouthpiece via a metering chamber. A metered quantity of the aerosol compound is discharged into the metering chamber and this is conveyed to the mouthpiece via an inhalation-actuated valve.

GB 1269554 describes a device wherein the aerosol container is movable by a lever and can system into a charged position held by a latch, a pressure differential acting to trip the latch and move the valve of the container to a discharge position.

International Application No. PCT/GB91/02118 describes a metered dose inhaler in which an axially movable dose dispensing assembly is subjected to a preload capable of actuating the delivery means thereof. This preload is itself subjected to a resisting pneumatic force capable of preventing such actuation. A breath-actuated release valve is provided which, upon actuation, releases the resisting force to allow the preload to actuate the dose dispensing assembly. Inlet vents are provided in an outer housing of the device for passage of air through the housing to entrain a metered dose of medicament for inhalation by a patient. During use, when the device is carried in clothing pockets etc., foreign matter, such as fluff, may enter the outer casing through the air vents.

It is an object of this invention to provide an improved breath actuated inhaler in which means are provided to inhibit the ingress of foreign matter therein, in a relatively simple and convenient manner.

According to the present invention, there is provided a dispensing device for use with a drug delivery system, the dispensing device comprising a housing for receiving said drug

3

delivery system, the housing having air inlet means and a nozzle through which a dose of medicament entrained in an air flow is inhaled, in use, and having means for actuating said drug delivery system to dispense a dose of medicament, means for restraining said actuation means and means to release said restraining means, which release means, in one condition, close said air inlet means to inhibit ingress of foreign matter therethrough, and, in a second condition, actuate said release means to release said restraining means from restraining said actuation means thereby causing actuation of the drug delivery system, said release means being brought into said second condition from said first condition in response to inhalation through said nozzle.

Said release means may include a movable closure member which, in said one condition, covers said air inlet means. Said closure member may be pivotally mounted within said housing whereby suction pressure created in the housing as a result of inhalation at said nozzle acts on the closure member to cause it to pivot to uncover said air inlet means and to release said restraining means.

Said actuation means may comprise means for applying a preload capable of actuating said drug delivery system.

Said restraining means may comprise means for applying a resisting pneumatic force capable of preventing actuation of said actuation means. The pneumatic resisting means may be provided by a gas, e.g. air, which is either held at a positive pressure greater than atmospheric or a negative pressure below atmospheric prior to release. The release means will act to return the pressure to atmospheric or prior equilibrium, thus allowing the full force of the preload to act.

Said means for applying a resisting pneumatic force may comprise an expandable gas tight chamber, said release means including valve means which are opened, in said second condition, to release a negative pressure prevailing in said low pressure chamber.

This invention relates to a dispensing device, and more specifically, to a device suitable for dispensing discrete amounts of fluid or particulate material entrained in an air flow. In particular, the invention is concerned with a dispensing device of the type where the metered dose is administered in response to the inhalation of the patient.

Metered dose inhalers are well known in medicine for treatment, or alleviation of the effects of respiratory complaints, for example asthma. Breath-actuated devices are also known, and have been the subject of many patent applications.

GB 1288971; GB 1297993; GB 1335378; GB 1383761; GB 1392192; GB 1413285; WO 85/01880; GB 2204799; US 4803978 and EP 0186280A describe inhalation-actuated dispensing devices for use with a pressurized aerosol dispensing container. The device includes a dispensing container and the container includes a valve capable of releasing a metered amount of the aerosol contents, when an internal spring operating the valve is compressed by a sufficient amount. The dispensing device often comprises a chamber having a mouthpiece, air inlets, actuating means for causing the actuation of the valve in the dispensing container, a latching means for releasably retaining said metering valve in a charged position, and an inhalation responsive means for releasing the latch, such that a metered amount of aerosol compound is discharged into the region of the mouthpiece. The overall objective is to give coordination of discharge of medicament from the aerosol container with inhalation of the patient, thus allowing a maximum dose of medicament to reach the bronchial passages of the lungs.

The latching means is often connected to a valve which moves from a latching position to a dispensing position in response to a partial vacuum developed upon inhalation.

Although this device has been described in particular relation to a system using air, it will be realized that in a closed system any suitable gas could be used.

A device according to the invention is particularly suited for use with pressurized inhalation aerosols having valves which can be actuated to dispense a dose of medicament. However in other embodiments, a device according to the invention can be used with a dry powder drug delivery system disposed within said housing, in which a dose of powdered medicament is dispensed by said system into an air flow in said housing created by inhalation at said nozzle.

In some arrangements according to the invention for use with an aerosol dispensing container, the housing may include an inner sleeve for enclosing the main body of the aerosol container to define a chamber for the aerosol container. The chamber may be defined at one end by a cross member which accommodates the valve of the aerosol and seals the chamber apart from providing an aerosol outlet. The inner sleeve is preferably sealed such that there is sliding airtight contact with the sleeve chamber such that the aerosol container and inner sleeve provide a piston effect against the cross member to form the resisting load in the form of a high pressure volume capable of preventing the actuation of the aerosol valve.

In other arrangements according to the invention for use with an aerosol dispensing container, the housing may include an inner sleeve for enclosing the top portion of the main body of the aerosol container. This inner sleeve is preferably arranged to form one end of an airtight piston cylinder, bellows or diaphragm, such that movement of the inner sleeve will result in an increase in the enclosed volume within the piston cylinder, bellows or diaphragm producing a vacuum or low pressure volume to form the resisting load (force) capable of preventing the actuation of the aerosol valve.

In some embodiments, the sleeve for the dispenser may act as a sliding, airtight piston, except that instead of

providing a high pressure volume, downwards motion away from the main casing creates a low pressure volume.

In a preferred arrangement, the pneumatic resisting means is formed by the inner sleeve and a fixed insert in the outer chamber linked together by flexible bellows or by a sliding airtight seal between the sleeve and a cylinder-like extension to the insert.

According to a feature of the invention, the preload may be provided by a spring which operates, for example, against the aerosol valve. Preferably the preload is applied by a lever, pivoted in a recess housed in the outer chamber. The lever may take the form of a restraining lever preventing a loaded spring from acting on the aerosol can until operated. After operation the lever is used to reload the spring. Alternatively the lever may be connected via a plug to a spring which is in contact with the inner sleeve such that movement of the lever loads the spring.

The release means may comprise a valve port in the aforesaid cross member. The valve port may normally be covered by a flexible valve flap which on actuation is opened, allowing the preload to actuate the aerosol valve as pressure in the pneumatic means returns to the rest state. In the embodiment wherein the resisting force is a positive pressure of air, opening of the valve port releases the built-up pressure, and air escapes from the enclosed volume, allowing the full force of the preload to act against the aerosol valve. In the embodiment wherein the resisting force is a vacuum or near vacuum, opening of the valve port allows air to enter the enclosed volume, again allowing the full force of the preload to act against the aerosol valve.

A preferred breath-actuating release means comprises a movable vane mechanism. This vane mechanism may be housed in the lower or upper part of the chamber, depending upon the location of the resisting element. A valve seal is preferably attached to said vane, such that on inhalation the vane moves from its rest position closing said inlet means to its actuating position, thus moving the valve seal out of contact

with the valve port, causing the opening of the valve. The vane mechanism is preferably dynamically balanced, and may be biased towards its closed position, e.g., by a spring.

Said air inlets may take the form of slots in the wall of said housing.

The medicament may be a drug per se or on any form of carrier, e.g., including a powder or a gaseous carrier.

The invention will now be described by way of example only, with reference to the accompanying drawings, in which:-

Figure 1 is a perspective view of an inhaler of the type to which the invention is applied;

Figure 2 is a sectional view of a first embodiment of the invention;

Figure 3 is an enlarged view of a diaphragm for use with the embodiment shown in Figure 2;

Figure 4 is a sectional view of a second embodiment of an inhaler according to the invention; and

Figures 5A and 5B are diagrammatic details partly in section of the upper and sections of the inhalers of Figures 2 and 4, respectively.

Referring to Figures 1 and 2 of the drawings, there is shown an inhalation device which is essentially similar in construction and operation to the device described in International Patent Application No. PCT/GB91/02118 (the disclosure of which is incorporated herein by reference) with reference to Figures 3 to 5 thereof. The modification thereof according to the present invention will be described below.

The inhalation device consists of a main body or housing 400 which is generally cylindrical in cross section, with a mouthpiece section 405 at one end and an end cap 407 housing air inlets 420 at the other end. A known type of aerosol dispensing container 25 of generally cylindrical shape is housed within the main body of the device. The aerosol dispensing container has a stem 40 which contains an aerosol dispensing valve (not shown). The bore 15 is such that it forms an airtight seal on the stem 40 of the aerosol dispensing container 25. A shoulder 45 limits and locates the

position of the stem 40, which in turn locates the aerosol dispensing container 25 in position in the main body 400. A passage 50 extends from the bore 15, continuing from the shoulder 45 to interconnect with a dispensing nozzle 55.

The opposite end of the dispensing container is contained within a sleeve 420 of similar cross section to the main body 400. The longitudinal axis of both the sleeve 420 and main body 400 is generally coaxial. The sleeve is in loose sliding contact with the inner wall of the main body to allow free passage of air in the main body past the sleeve. The sleeve 420 may be held in place by connection with a diaphragm 440 held in connection with the top of the main body 400, as will now be described. Thus, the sleeve 420 effectively hangs from the top of the main body.

One end of an e.g., moulded flexible diaphragm 440 (as shown alone in Figure 4) comprising a rigid disc-like section 441, a flexible generally cylindrical wall section 445 and a stiffer connector section 447, is fitted around a purpose-made groove 450 in the sleeve, e.g. by snap-fitting. A further moulded lip 470 on the diaphragm provides a snug fit for one end of a compression spring 460. The compression spring is thus located and free to act on the sleeve. The other end of the compression spring is located by an annular shoulder 481 in a predominantly cylindrical flanged insert 480 housed in the top section of the main body 400. This insert includes a groove 490 into which the disc-like section 441 of the flexible diaphragm 440 is snap-fitted.

The joint between the diaphragm connector section 447 and inner sleeve groove 450 is arranged to be airtight and the shape of the top surface 422 of the sleeve to conform to the internal shape of the diaphragm such that in the rest position of the inhaler the two surfaces are in close proximity, and the enclosed space between them very small.

The cylindrical insert 480 is retained in place by the end cap 407 of the main body of the device. This forms a chamber 590 between the air inlet slots 420 and the rigid part 441 of the diaphragm. The chamber is provided with one or

more air pathways 580 such that air may pass from the air inlet slots 420 to the mouthpiece 405. The rigid disc-like section 441 of the diaphragm also includes a small valve port 495 which is normally covered by a valve seal (flap) 540 provided on an actuating closure lever pivotally connected to the insert 480. The closure lever is generally L-shaped with a first leg 600 providing the valve seal 540. The second leg 601 of the lever is provided, at its free end, with a lateral closure flap 602 adapted to close the two sets of air inlets 420 into the housing 400, in the rest of the lever 550 in which the valve seal 540 closes valve port 495.

The closure lever 550 in its rest position is subjected to a pressure drop created between the air inlets 420 and the mouthpiece 405 when a user inhales at the mouthpiece. In this way, the ingress of fluff or other foreign matter into the housing 400, through the air inlet slots 420, is inhibited in a particularly convenient manner. On movement of the lever to the actuated position the valve seal (flap) 540 is sufficiently moved to open the valve port 495. (The valve 550 may be biased closed by a light spring flexure, a weight or a magnet not shown).

As shown in Figure 2, the end of the main body 400 having a pivot 500, has a recess adapted to receive a can 520 integral with a dust cap 510 operating on the pivot. The recess further includes a passage communicating with a similar passage moulded into the internal wall of the main body 400. A can follower 530 extending from the lower edge of the inner sleeve 420 acts on the can such that when the dust cap is in the closed position the inner sleeve is forced by the can follower to its uppermost position.

When the dust cap is rotated to its open position the can profile is such that the can follower is free to move downwards by an amount sufficient to allow actuation of the device.

In its rest position with the dust cap 510 closed, the can follower 530 restrains the inner sleeve 420 in its uppermost position such that the enclosed space trapped

from its rest position to its actuated position. The lever and the design of the air passageway 580 in the chamber 590 are such that in the actuated position air can flow freely from the air inlets 420 to the patient.

The movement of the lever 550 causes the valve seal (flap) 540 to be moved out of a sealing position with the valve port 495. Opening the valve port allows air into the space created between the diaphragm 440 and the inner sleeve 420 such that the enclosed space reaches atmospheric pressure. This causes an imbalance of forces acting on the sleeve 420 and container 25. The sleeve and container are thus forced downwards by the spring 460 resulting in the release of a measured dose of medicament through the dispensing nozzle 55 and into the mouthpiece at the same time as the patient breathes in. Thus the patient inhales air with a metered dose of medicament.

After the inhalation of the dose by the patient, the dust cap 510 is returned to its closed position. This rotates the can 520 and causes the can follower 530 to be forced upwards. This in turn acts on the inner sleeve 420 moving it upwards to compress the spring 460 and to close the space defined between the diaphragm 440 and inner sleeve top surface 422. This forces air out of that space which escapes through the valve port 495. The aerosol can is free to return to the rest position under the action of its own aerosol valve spring.

In use the patient loads the aerosol dispensing container into the main body. The aerosol container may be loaded by providing a coarse threaded screw between upper and lower sections of the main body 400. When part of the main body 400 has been unscrewed, the aerosol can is inserted. The main body 400 can then be replaced locating the inner sleeve over the top end of the can, and the device is ready for use. As described previously, the device could be manufactured as a sealed unit.

The device may be provided with means to provide a regulated air flow to the user or inhaler. Thus a sonic device, e.g., a reed, may be provided which sounds when the

between the diaphragm 440 and the top surface 422 of the inner sleeve is at a minimum and the spring 460 is compressed. The valve port 495 is closed by the valve seal (flap) 540 and the sleeve 420 is clear of the top of the aerosol can 25 which is thus unloaded.

When the dust cap is opened the integral can 520 is rotated thereby allowing the can follower 530 to drop by amount AA. The inner sleeve is forced downwards under the action of the spring 460. As the inner sleeve moves downwards the enclosed volume between the diaphragm 440 and inner sleeve is increased by a linear equivalent amount A'A', less than or equal to AA. Since the valve port 495 is closed this creates a low pressure volume or near vacuum in the space created between the diaphragm 440 and the upper surface 422 of the sleeve 420. The effect of the pressure differential between the enclosed volume 600 and atmospheric pressure is such that the inner sleeve tends to resist the action of the spring. As the inner sleeve moves downwards it contacts the aerosol can 25 and begins compression of the aerosol valve (not shown).

Downward movement of the inner sleeve will continue until there is a balance of forces between the compressive force in the spring 460 and resisting forces created by the pressure differential and compression of the aerosol valve. The geometry of the device is arranged such that this balance occurs before the aerosol valve has been sufficiently compressed to actuate it.

A typical aerosol requires about 20N force to actuate. The spring 460 should accordingly provide a greater force, preferably 10% to 50% greater.

It may also be possible to arrange for the balance of forces to take place before the inner sleeve has contacted the aerosol can, such that the spring force is balanced by the resisting force produced on the inner sleeve by virtue of the pressure differential.

On inhalation by the patient through the mouthpiece 405, a small pressure differential is created across the closure lever. The pressure differential causes the lever to move

inspired air flow is greater than a pre-set level, e.g., above 30 to 50 litres per minute. The sonic device may be located in the mouthpiece 95 or below the air inlet 420. The sound produced warns the patient to breathe at a lower rate.

The device may also be provided with a means such that it will not operate below a certain predetermined air flow rate, e.g., 10 to 30 litres per minute. In one embodiment the closure lever 550 may be biased by a spring such that the predetermined minimum air flow is necessary for it to move to its actuated position and enable the valve seal to open.

The main body of a dispensing device, as described in the first or second embodiment of this invention is preferably manufactured from a plastic such as polypropylene, acetal or moulded polystyrene. It may however be manufactured from metal or another suitable material.

The inhaler illustrated in Figure 4 is generally similar to that illustrated in Figure 2 and like parts have been given similar reference numerals. In this construction, a different closure member and flap valve assembly is utilised. The closure member comprises a first lever 700 having a flap section 701 for closing the air inlet slots 420, in a rest position. The lever is pivotally mounted on the insert 480. The lever has a short downwardly projecting leg formed with a lateral projection 702 for interengaging with an upwardly projecting leg 703 of a second L-shaped lever also pivotally mounted on the insert 480.

The second lever carries on its horizontal leg 704 a diaphragm valve closure member 705 for sealing with an annular valve seat 706 which is upstanding from the upper surface of the flexible diaphragm 440 and encircles the outlet end of the valve port 490.

In this arrangement, inhalation at the mouthpiece 405 causes the first lever to rotate in a clockwise direction as seen in Figure 4. This in turn causes the second lever to rotate in the same direction thereby eventually lifting the valve closure member 705 off the annular valve seat 706. This releases the negative pressure in the chamber than defined

between the flexible diaphragm 440 and the upper surface of the insert 420 from which it is then spaced, to allow the sleeve 420 and the container 25 to be moved downwardly under the unrestrained action of the spring 460. This results in a measured dose of medicament being delivered into the mouthpiece 405, in a similar fashion to the operation described above for the embodiment of Figures 2 and 3.

The embodiment of Figure 4 has the advantage over the embodiment of Figures 2 and 3, that it provides a larger effective area, whereby a relatively lower flow and/or lower pressure drop is required to actuate the device.

CLAIMS

1. A dispensing device for use with a drug delivery system, the dispensing device comprising a housing for receiving said drug delivery system, the housing having air inlet means and a nozzle through which a dose of medicament entrained in an air flow is inhaled, in use, and having means for actuating said drug delivery system to dispense a measured dose of medicament, means for restraining said actuation means and means to release said restraining means, which release means, in one condition, close said air inlet means to inhibit ingress of foreign matter therethrough, and, in a second condition, actuate said release means to release said restraining means from restraining said actuation means thereby causing actuation of the drug delivery system, said release means being brought into said second condition from said first condition in response to inhalation through said nozzle.

2. A dispensing device according to Claim 1 wherein said release means includes a movable closure member which, in said one condition, covers said air inlet means.

3. A dispensing device according to Claim 2 wherein said closure member is pivotally mounted within said housing whereby suction pressure created in the housing as a result of inhalation at said nozzle acts on the closure member to cause it to pivot to uncover said air inlet means and to release said restraining means.

4. A dispensing device according to any one of Claims 1 - 3 wherein said actuation means comprises means for applying a preload capable of actuating said drug delivery system.

5. A dispensing device according to any one of Claims 1 - 4 wherein said restraining means comprise means for

applying a resisting pneumatic force capable of preventing actuation of said actuation means.

6. A dispensing device according to Claim 5 wherein the pneumatic resisting force is provided by air which is either held at a positive pressure greater than atmospheric or a negative pressure below atmospheric prior to release.

7. A dispensing device according to Claim 5 or Claim 6 wherein said means for applying a resisting pneumatic force comprises a low pressure chamber, said release means including valve means which are opened, in said second condition, to release a negative pressure prevailing in said low pressure chamber in said one condition.

8. A dispensing device as claimed in any one of the preceding Claims, wherein the housing provides a chamber for receiving said drug delivery system in the form of an aerosol container, the chamber being defined by an inner sleeve slidably mounted within the housing, the inner sleeve at least partly enclosing the main body of the aerosol container.

9. A dispensing device as claimed in any one of Claims 1 - 8 wherein said actuating means comprises resilient means for actuating the drug delivery system on release of said release means.

10. A dispensing device as claimed in Claims 6 and 8 wherein said resisting pneumatic pressure is a positive pressure created by cooperation of between inner sleeve and a cross member provided in the housing to form a piston and cylinder assembly.

11. A dispensing device as claimed in Claim 10 wherein said actuating means comprise a lever pivotally mounted on the housing, the lever being movable to preload a spring for exerting a pressure on the drug delivery system.

12. A dispensing device as claimed in Claim 6 or Claim 7 wherein said pneumatic resisting force is a negative pressure created inside an expandable airtight volume defined by a bellows, piston, cylinder or diaphragm.

13. A dispensing device according to Claim 8 wherein said actuating means include a spring acting on said inner sleeve, and wherein means are provided for resetting said actuating means after release thereof to cause actuation of the drug delivery system.

14. A dispensing device according to Claim 13 wherein a cover for said nozzle is movably mounted on said housing, and a control member associated with said inner sleeve cooperates with a cam formation provided on the cover such that, when the cover is closed, the control member moves the inner sleeve to compress said spring and, when the cover is opened, the inner sleeve is moved under the action of the spring until the forces acting on the inner sleeve, including said pneumatic resisting force are balanced, preparatory to release of the pneumatic resisting force in response to inhalation at said nozzle.

15. A dispensing device substantially as hereinbefore described with reference to Figs. 1 - 3, or Figs. 1 - 3 when modified as in Fig. 4 or Fig. 5A or Fig. 5B, of the accompanying drawings.

16. A dispensing device according to any one of the preceding claims in combination with a drug delivery system in the form of an aerosol dispensing container having a valve capable of being actuated to release a metered amount of the pressurized aerosol contents.

17. A dispensing device according to any one of Claims 1 - 7, 9 - 12 in combination with a dry powder drug delivery system disposed within said housing and adapted to dispense, when actuated, a dose of powdered medicament into an air flow in said housing created by inhalation at said nozzle.

Examiner's report to the Comptroller under
Section 17 (The Search Report)

9211435.4

Relevant Technical fields

(i) UK Cl (Edition K) AST TBE : TBD

(ii) Int Cl (Edition 5) A61M

Databases (see over)

(i) UK Patent Office

(ii)

Search Examiner

J A WALLIS

Date of Search

12 AUGUST 1992

Documents considered relevant following a search in respect of claims

1 AT LEAST

Category (see over)	Identity of document and relevant passages	Relevant to claim(s)
X	GB 2204799 A (GLAXO ETC) Closure plate 79	1-4, 8, 9 at least
X	GB 1383761 (WOODCRAFT) Closure plate 61	1-4 at least
X	GB 1288971 (ARMS RONG KROPP) Closure 15 or 165	1-4 at least
X	GB 1269811 (RINKER ETC) Element 66 or 93	1-4, 8, 9 at least
X	EP 0045419 A1 (FISORS ETC) Piston 15 acts as a closure for ports 33, 34	1, 2, 4, 8, 5 13 at least

SFZ(p)

GH - doc99\fl1000227

17

Category	Identity of document and relevant passages	Relevant to claim(s)

Categories of documents

X: Document indicating lack of novelty or of inventive step.
 Y: Document indicating lack of inventive step if combined with one or more other documents of the same category.
 A: Document indicating technological background and/or state of the art.

P: Document published on or after the declared priority date but before the filing date of the present application.
 E: Patent document published on or after, but with priority date earlier than, the filing date of the present application.
 S: Member of the same patent family, corresponding document.

Databases: The UK Patent Office database comprises classified collections of GB, EP, WO and US patent specifications as outlined periodically in the Official Journal (Patents). The on-line databases considered for search are also listed periodically in the Official Journal (Patents).